

Approval body for construction products
and types of construction

Bautechnisches Prüfamt

An institution established by the Federal and
Laender Governments



European Technical Assessment

ETA-13/0196
of 25 January 2022

English translation prepared by DIBt - Original version in German language

General Part

Technical Assessment Body issuing the
European Technical Assessment:

Deutsches Institut für Bautechnik

Trade name of the construction product

ancoPLUS punching reinforcement

Product family
to which the construction product belongs

Double headed studs as punching reinforcement

Manufacturer

ANCOTECH GmbH
Am Westhover Berg 30
51149 Köln
DEUTSCHLAND

Manufacturing plant

ANCOTECH Herstellwerke

This European Technical Assessment
contains

17 pages including 3 annexes which form an integral part
of this assessment

This European Technical Assessment is
issued in accordance with Regulation (EU)
No 305/2011, on the basis of

EAD 160003-00-0301, Edition: 05/2018

This version replaces

ETA-13/0196 issued on 3 September 2020

The European Technical Assessment is issued by the Technical Assessment Body in its official language. Translations of this European Technical Assessment in other languages shall fully correspond to the original issued document and shall be identified as such.

Communication of this European Technical Assessment, including transmission by electronic means, shall be in full. However, partial reproduction may only be made with the written consent of the issuing Technical Assessment Body. Any partial reproduction shall be identified as such.

This European Technical Assessment may be withdrawn by the issuing Technical Assessment Body, in particular pursuant to information by the Commission in accordance with Article 25(3) of Regulation (EU) No 305/2011.

Specific Part

1 Technical description of the product

The ANCOPLUS double headed studs with ribbed shafts are made of weldable ribbed reinforcement bars with nominal characteristic yield strength of 500 MPa. The mechanical properties of the steel used meet the requirement according to EN 1992-1-1:2004 + AC:2010, section 4.4.

They have a head at both ends with a diameter of three times the shaft diameter.

The diameters of the shafts are 10, 12, 14, 16, 20 and 25 mm.

The studs are assembled to form reinforcement elements comprising at least two studs. All studs of one of those reinforcement element shall have the same diameter.

The following variants of assembling the reinforced elements are considered:

a) Double headed studs with steel bars welded to the head:

The studs are tack welded at one head to non-structural steel bars $d_s = 6$ mm to 10 mm for securing the position of the double headed studs when pouring the concrete.

b) Double headed studs with steel bars welded to the shaft.

The studs are spot-welded at the shaft to non-structural steel bars with a diameter $d_s = 6$ mm (studs with a diameter $d_A < 20$ mm) and $d_s = 8$ mm (studs with $d_A \geq 20$ mm). The distance between the anchor head in the compression zone and the welded reinforcement bars shall not exceed 80 mm.

The material for the steel bars shall be reinforcing steel (according to EN 1992-1-1:2004 + AC:2010, section 4.4) or smooth steel bars (structural steel) with material No. 1.0037, 10038 or 1.0045 according to EN 10025-2:2019 or non-corrosive steel No. 1.4401, 1.4404, 1.4439, 1.4571 according to EN 10088-5:2009.

c) Spacer asDUO - Clip

The asDUO® Clip spacer are made of grey plastic. They are useful for ancoPLUS® double head anchors with the diameter 10 – 20 mm and a concrete cover from 15 – 50 mm.

The detailed product description is given in Annex A.

2 Specification of the intended use in accordance with the applicable European Assessment Document

The performances given in Section 3 are only valid if the Product is used in compliance with the specifications and conditions given in Annex B.

The verifications and assessment methods on which this European Technical Assessment is based lead to the assumption of a working life of the Product of at least 50 years. The indications given on the working life cannot be interpreted as a guarantee given by the producer, but are to be regarded only as a means for choosing the right products in relation to the expected economically reasonable working life of the works.

3 Performance of the product and references to the methods used for its assessment

3.1 Mechanical resistance and stability (BWR 1)

Essential characteristic	Performance
Increasing factor for punching shear resistance	$k_{pu,sl} = 1,96$ $k_{pu,fo} = 1,50$
characteristic fatigue strength for $N = 2 \cdot 10^6$ load cycles	$\Delta\sigma_{Rsk,n=2 \cdot 10^6} = 70 \text{ MPa}$

3.2 Safety in case of fire (BWR 2)

Essential characteristic	Performance
Reaction to fire	class A1

4 Assessment and verification of constancy of performance (AVCP) system applied, with reference to its legal base

In accordance with EAD No. 160003-00-0301 the applicable European legal act is: [97/597/EC(EU)].

The system(s) to be applied is (are): [1+]

5 Technical details necessary for the implementation of the AVCP system, as provided for in the applicable EAD

Technical details necessary for the implementation of the AVCP system are laid down in the control plan deposited with Deutsches Institut für Bautechnik.

Reference Documents

EN 10025-2: 2019-10	Hot rolled products of structural steels - Part 2: Technical delivery conditions for non-alloy structural steels
EN 206:2013 + A1:2016	Concrete - Specification, performance, production and conformity
EN 1992-1-1:2004 + AC:2010	Design of concrete - Part 1 -1: General rules and rules for buildings
EOTA TR 060:2017-11	Increasing the punching shear resistance of flat slabs or foundation and floor slabs – double- headed anchor- calculation methods

Issued in Berlin on 25 January 2022 by Deutsches Institut für Bautechnik

Dipl.-Ing. Beatrix Wittstock
Head of Section

beglaubigt:
Schüler

Dimensions of the ancoPLUS anchor

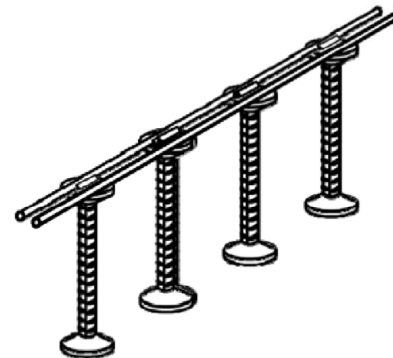
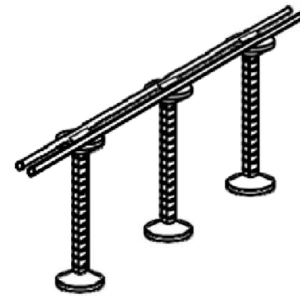
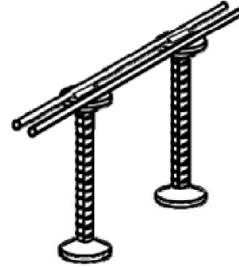
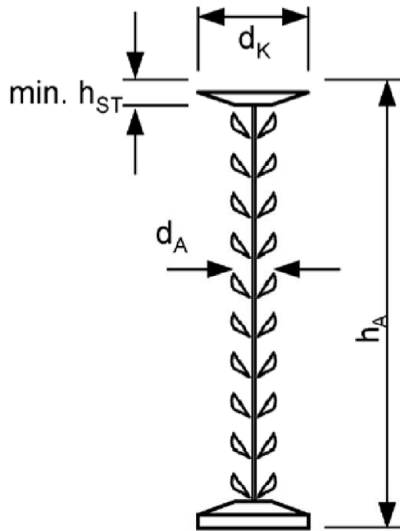

Markings of the ancoPLUS anchor:

E.g. or

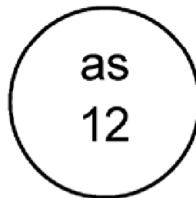
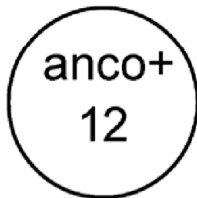

Anchor $\varnothing d_A$ [mm]	Head $\varnothing d_K$ [mm]	Head thickness min. h_{ST}	Anchor cross- section $A_{S,DKA}$ [mm ²]	Nominal yield strength f_{yk} [N/mm ²]	Anchor height h_A [mm]
10	30	5	79	500	$h_A =$
12	36	6	113		Plate thickness -
14	42	7	154		Concrete cover top -
16	48	7	201		Concrete cover
20	60	9	314		bottom
25	75	12	491		

Concrete reinforcing steel with a char. yield strength of $f_{yk} = 500$ MPa acc. to EN 1992-1-1, Annex C and deposited data sheet

ancoPLUS® punching shear reinforcement

Product description
ancoPLUS® Product dimensions and markings

Annex A1

Mounting rails made of reinforcing steel or round steel bars

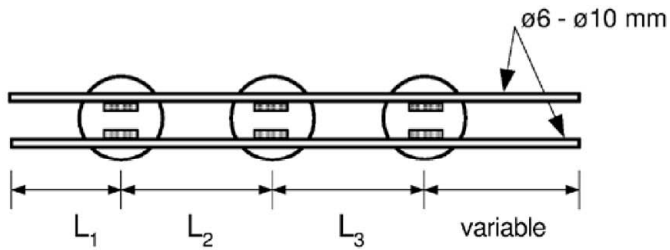

Material:

Structural steel:
S 235 JR (St37-2) = 1.0038
1.0038 acc. to EN 10025-2:2004

Stainless steel:
1.4571 / 1.4401 / 1.4462 / 1.4362
acc. to 10088-5:2009

Mounting rail configuration:

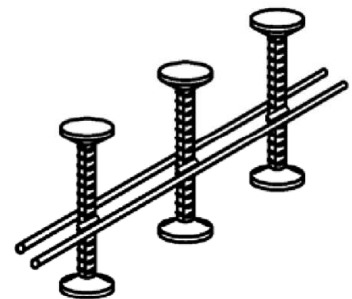
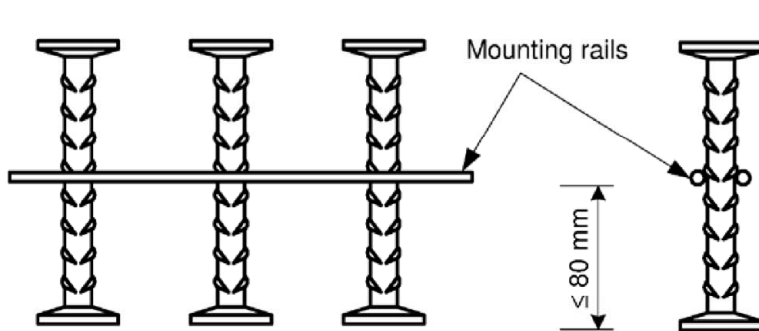
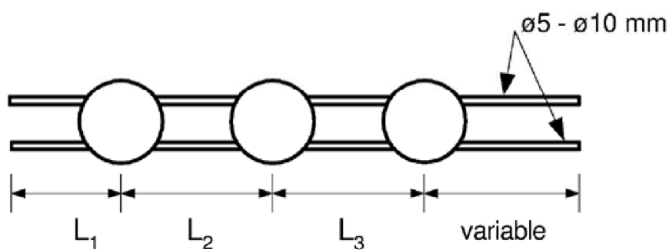
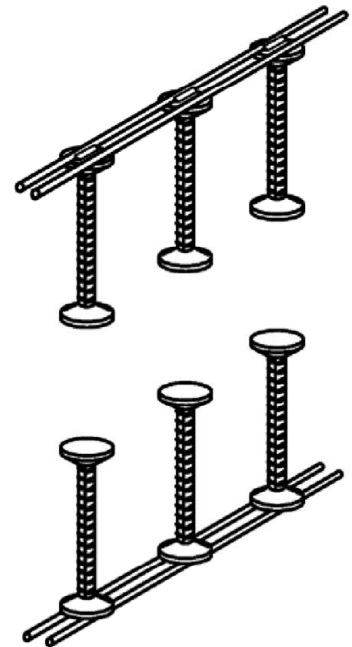
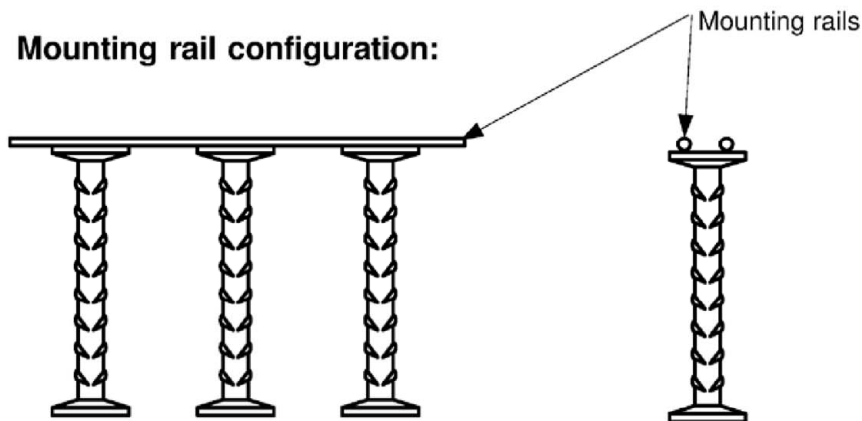

ancoPLUS® punching shear reinforcement

Mounting rail configuration

Annex A2

Spacer asDUO - Clip

Detail:

The asDUO® Clip spacer are made of grey plastic. They are useful for ancoPLUS® double head anchors with the diameter 10 – 20 mm and a concrete cover from 15 – 50 mm.

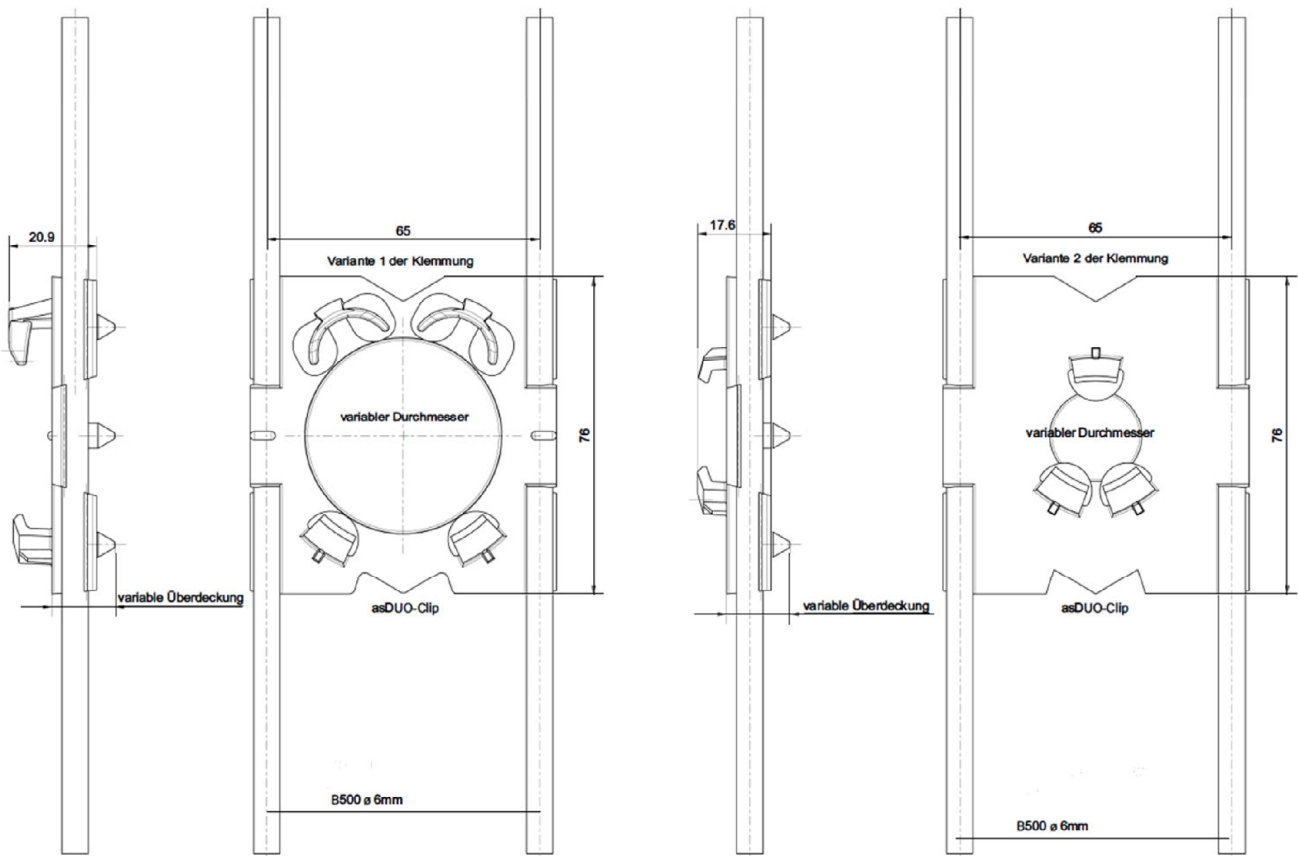

Installation:

The ancoPLUS® double head anchors will be fixed on an asDUO® Clip and installed with mounting rails. The system is useful in precast concrete plants.

ancoPLUS® punching shear reinforcement

Mounting aid spacer for using punching shear reinforcement in precast concrete plants

Annex A3

Specification of the intended use

Double head anchors are used to increase the punch shear load carrying capacity of flat ceilings or foundation and base plates under static, quasi-static and loads susceptible to fatigue.

Double head anchors are arranged next to the supports or concentrated single loads.

The dimensioning of the punch shear load carrying capacity of flat ceilings or foundation and base plates is carried out according to EOTA TR 060.

The intended use includes the following specifications:

- Flat ceilings or foundation and base plates made from reinforced normal concrete of strength class C20/25 to C50/60 according to EN 206-1:2000
- Flat ceilings or foundation and base plates with a minimum height of $h=180$ mm
- Double head anchor as reinforcement elements of the same diameter and type in punching shear area around the supports or concentrated single load
- Double head anchor as reinforcement elements, that are arranged in a vertical or suspended position (mounting iron on the head or shaft)
- Double head anchor as reinforcement elements that are positioned such that the double head pins are located vertically to the flat ceiling or foundation and baseplates
- Double head anchor as reinforcement elements that are arranged radially to the support or highly concentrated loads and are distributed equally in the critical punching shear area
- Double head anchor as reinforcement elements that are positioned such that the top heads of the pins reach at least to the outer side of the uppermost layer of the bending reinforcement
- Double head anchor as reinforcement elements that are positioned such that the bottom heads of the pins reach at least to the outer side of the lowest layer of the bending reinforcement
- Double head anchor as reinforcement elements that are positioned such that the concrete cover complies with the provisions according to EN 1992-1-1
- Double head anchor as reinforcement elements that are arranged such that the minimum and maximum distances between the double head pins on an element and between the elements around a support or an area with concentrated load correspond with the provisions according to Annex B3 to B7
- Deviations of the position and the distances between each other in the floor plan of the plates compared with the planning documents that is more than one tenth of the plate thickness are not permissible

ancoPLUS® punching shear reinforcement

Intended use
Specification

Annex B1

Installation:

When installed correctly, the anchors installed in the plate secure the position sufficiently and are resistant against the usual loading before concreting the plate.

When installing the double head anchor in the individual plates, no requirements are placed on the securing of the position and resistance previously mentioned if a reliable transport and the positioning of the anchor in the element plates has been ensured.

Packaging, transport and storage:

With the storage and transport of slab elements, the ancoPLUS® reinforcements must be observed that protrude beyond the lattice girders due to their height. The spacers necessary for the support of the slab elements must be raised accordingly.

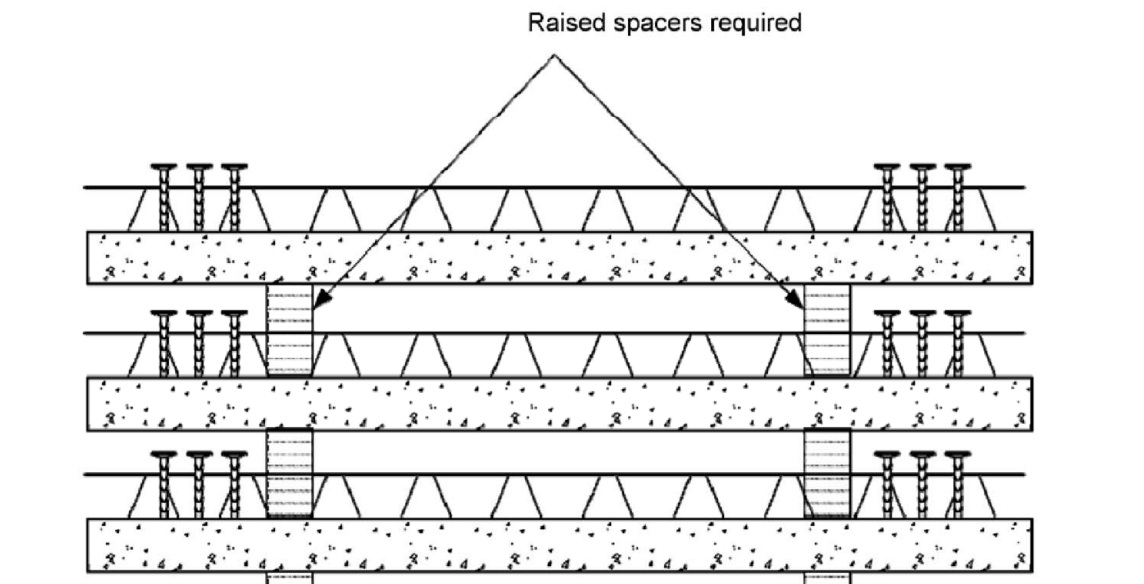

ancoPLUS® punching shear reinforcement

Intended use
Specification

Annex B2

Anchor arrangement

Two-anchor element

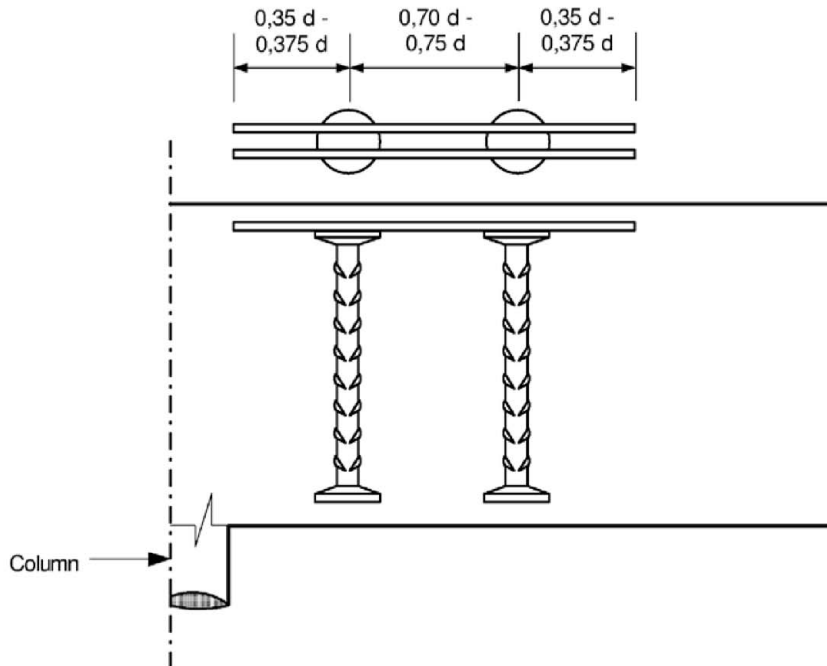

Three-anchor element

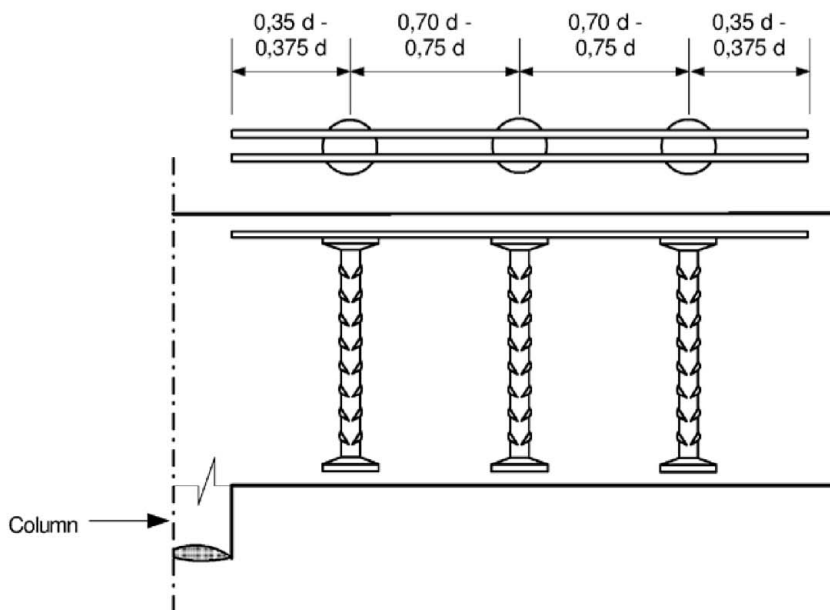

ancoPLUS® punching shear reinforcement

Distances between anchors

Annex B3

Punching shear reinforcement arrangement with complete elements in structural slabs

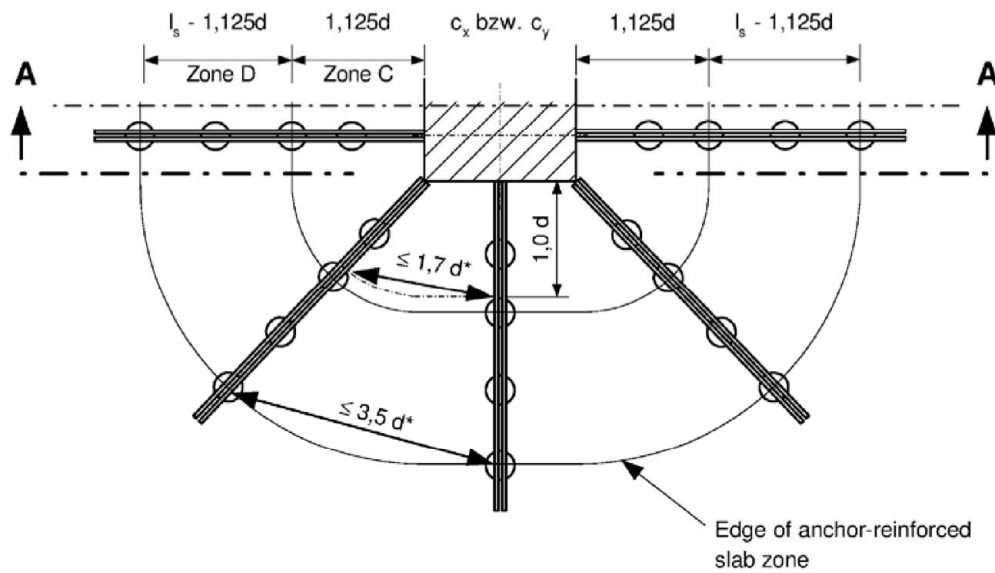

Section A-A

Installation from above:

Mounting rails positioned above the upper reinforcement

Installation from below:

Mounting rails positioned below the lower reinforcement

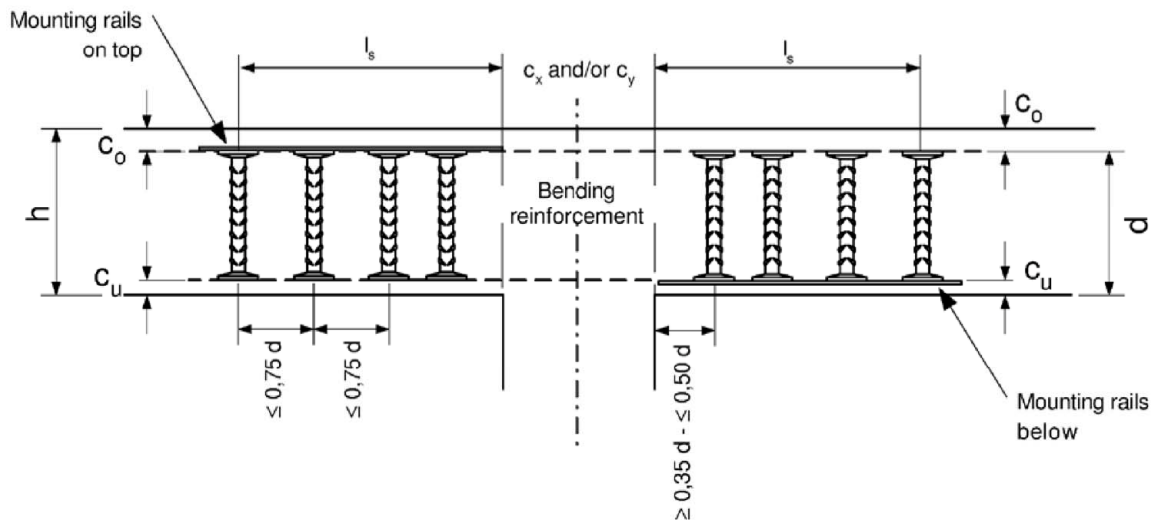

Concrete cover c_o and/or c_u in accordance with EN 1992-1-1:2004+AC:2010, section 4.4

ancoPLUS® punching shear reinforcement

Arrangement of reinforcing elements

Annex B5

Arrangement of the shear reinforcement with complete elements in individual foundations and base plates

Floorplan

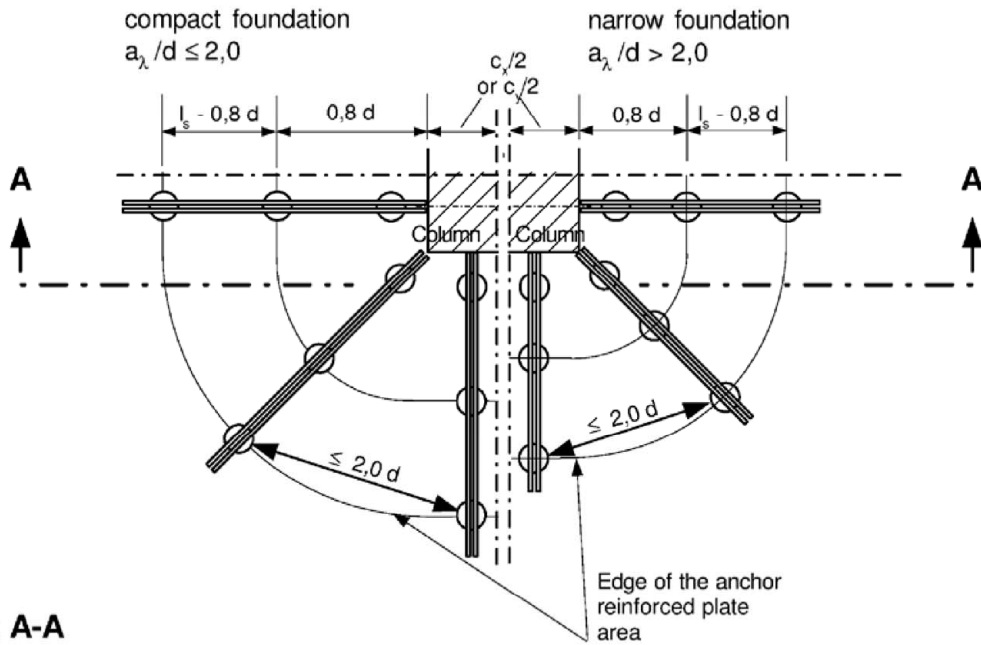

Section A-A

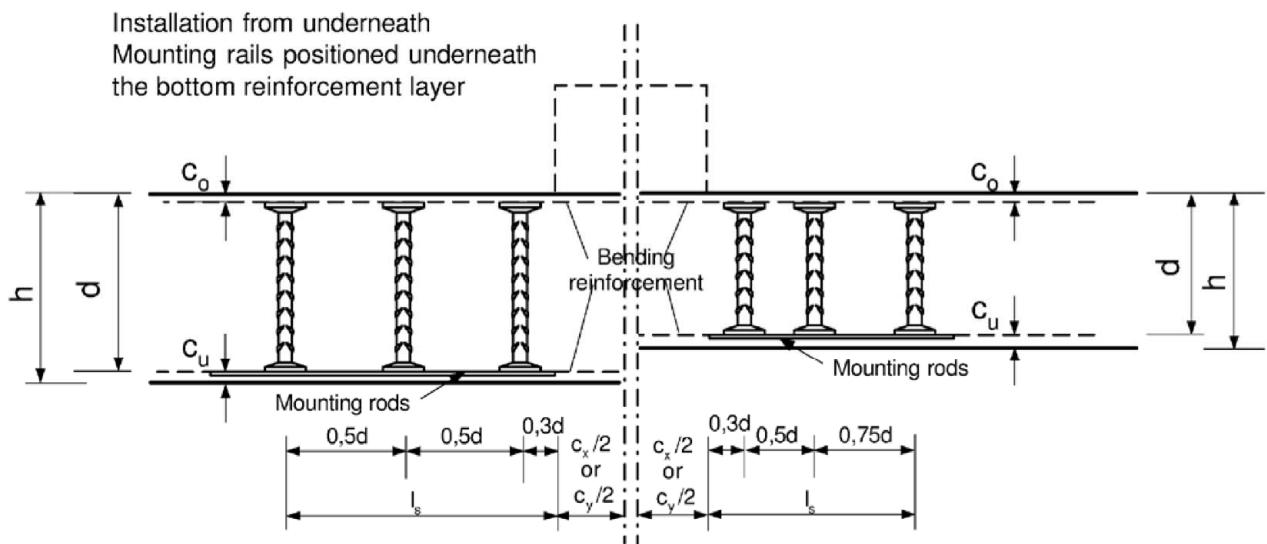

Concrete cover c_u or c_o according to EN 1992-1-1 : 2004 + AC : 2010, section 4.4

ancoPLUS® shear reinforcement

Intended use
ancoPLUS® arrangement in foundations and base plates

Annex B6

Parallel arrangement of the ancoPLUS® anchors

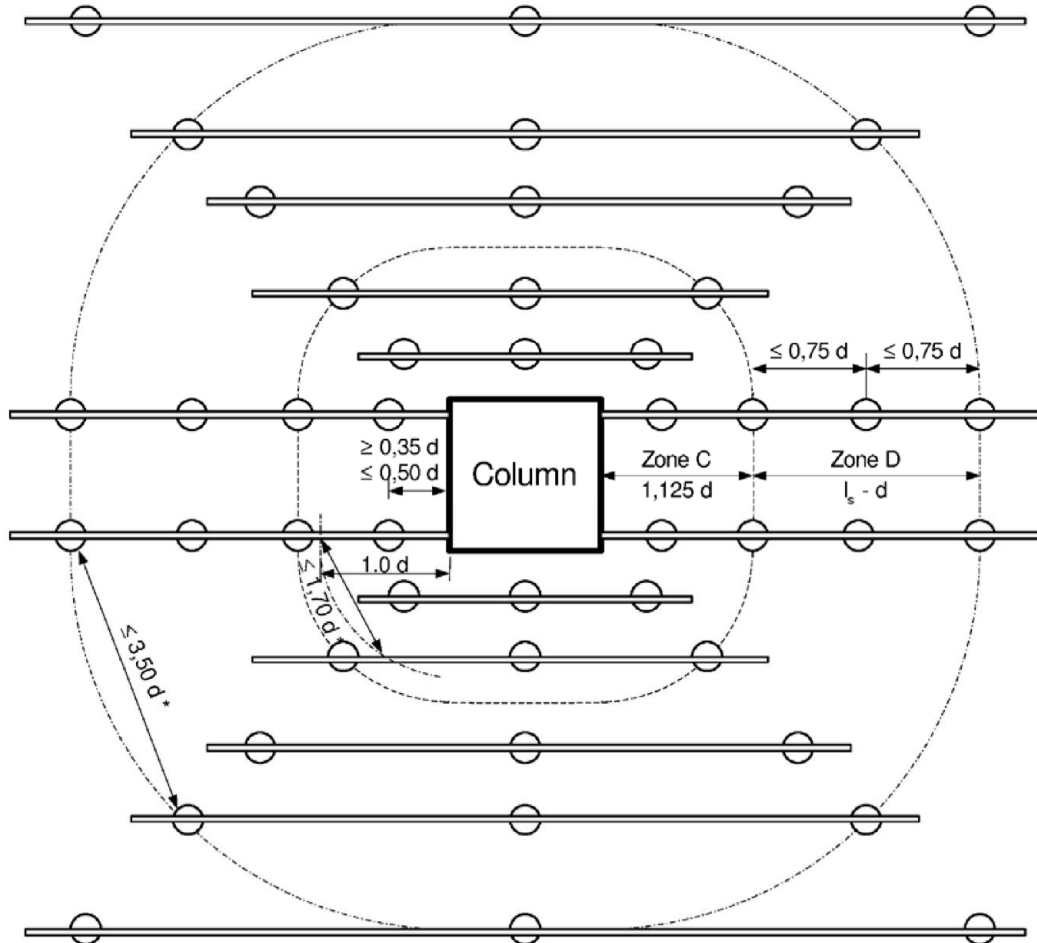

ancoPLUS® punching shear reinforcement

Parallel arrangement of the ancoPLUS® punching shear reinforcement

Annex B7

Determination of critical perimeters u_1 and u_{out} for calculation of theoretical shear stresses

1. Critical perimeter u_1 :

a) Loaded area (column) located more than $6d$ from openings or not close to free slab edges:

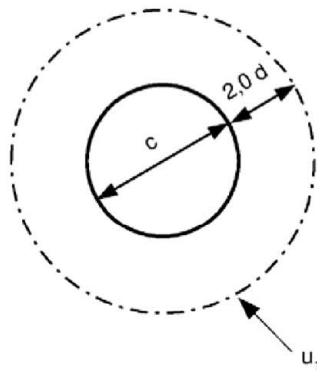

$$u_1 = \pi \times (c + 4d)$$

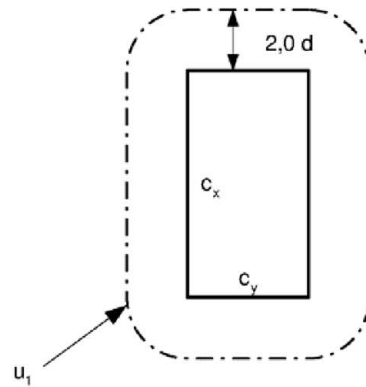

$$u_1 = 2 \times (c_x + c_y) + 4d_m \times \pi$$

a) Loaded area (column) located less than $6d$ from slab openings (recesses):

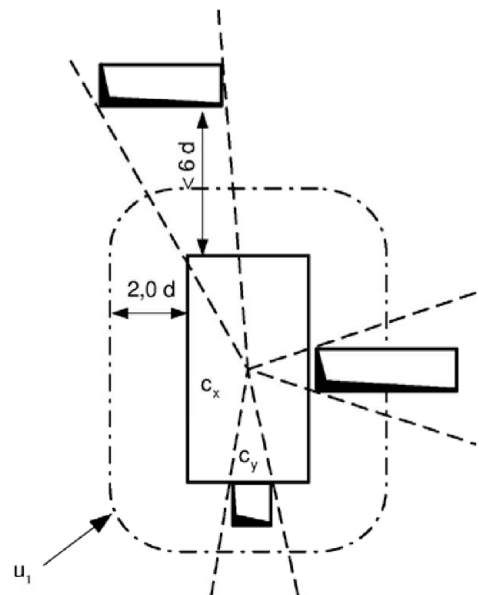
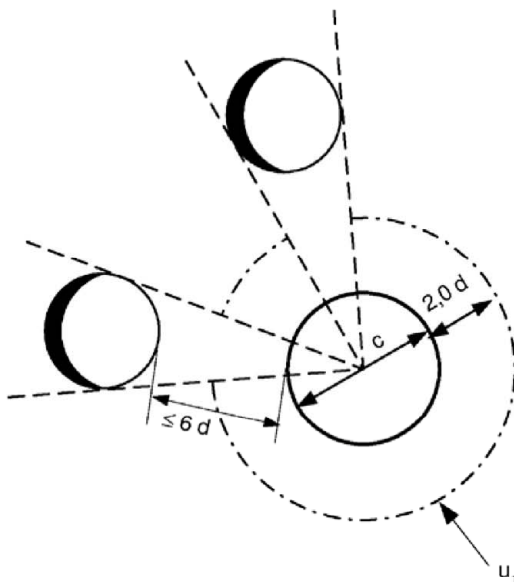

ancoPLUS® punching shear reinforcement

Critical perimeters

Annex C1

c) Loaded area (column) located close to free edges:

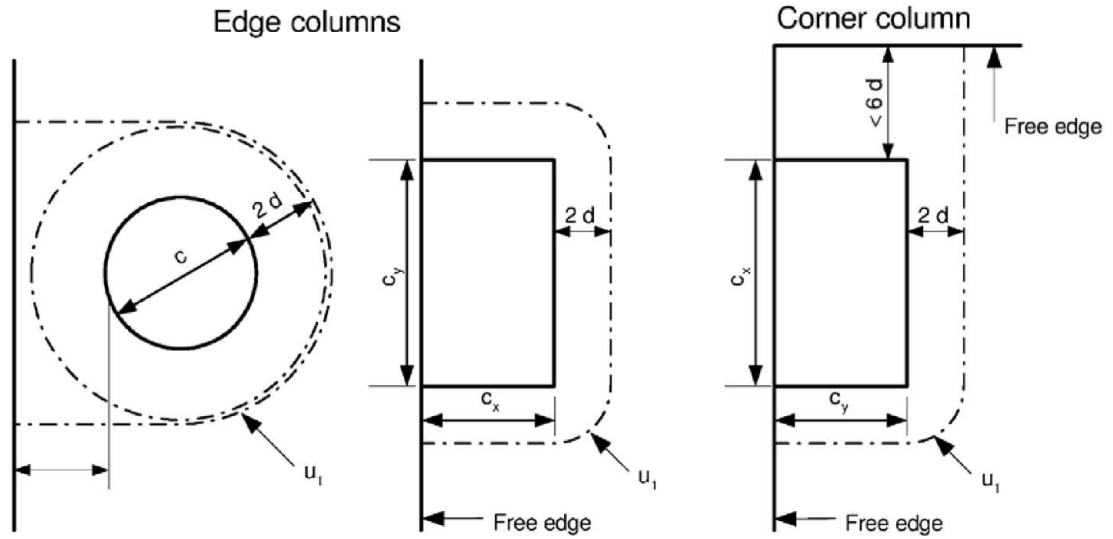

2. Outer perimeter u_{out}

a) Loaded area (column) located more than $6d$ from slab openings (recesses) or not close to free slab edges:

Round column

$$u_{out} = \pi \times (2 l_s + c + 3 d)$$

Rectangular column

$$u_{out} = 2 (c_x + c_y) + \pi (2 l_s + 3 d)$$

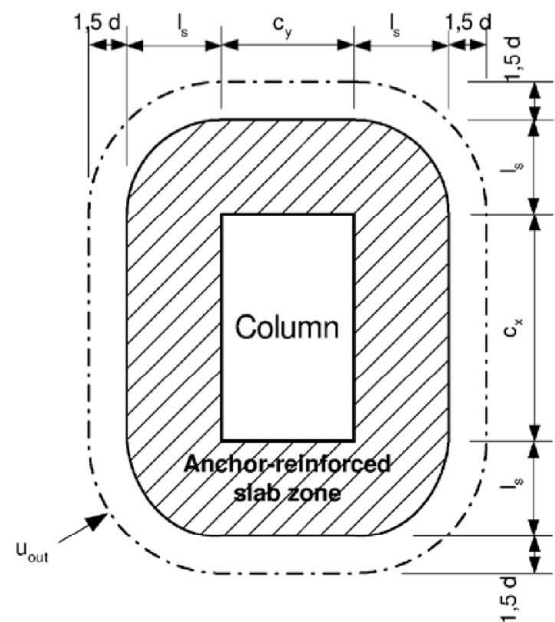
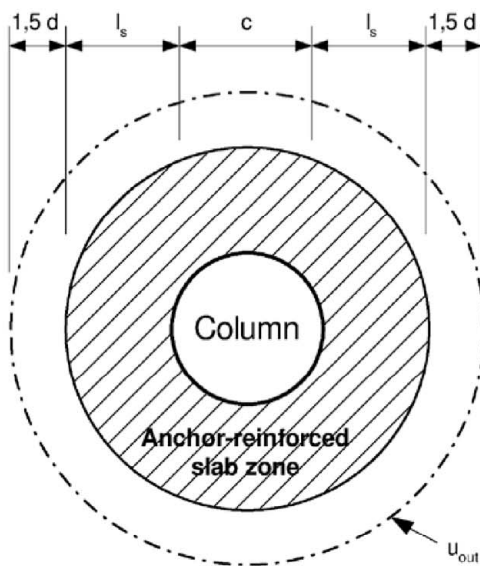

ancoPLUS® punching shear reinforcement

Outer perimeter

Annex C2

b) Loaded area (column) located less than $6d$ from slab openings:

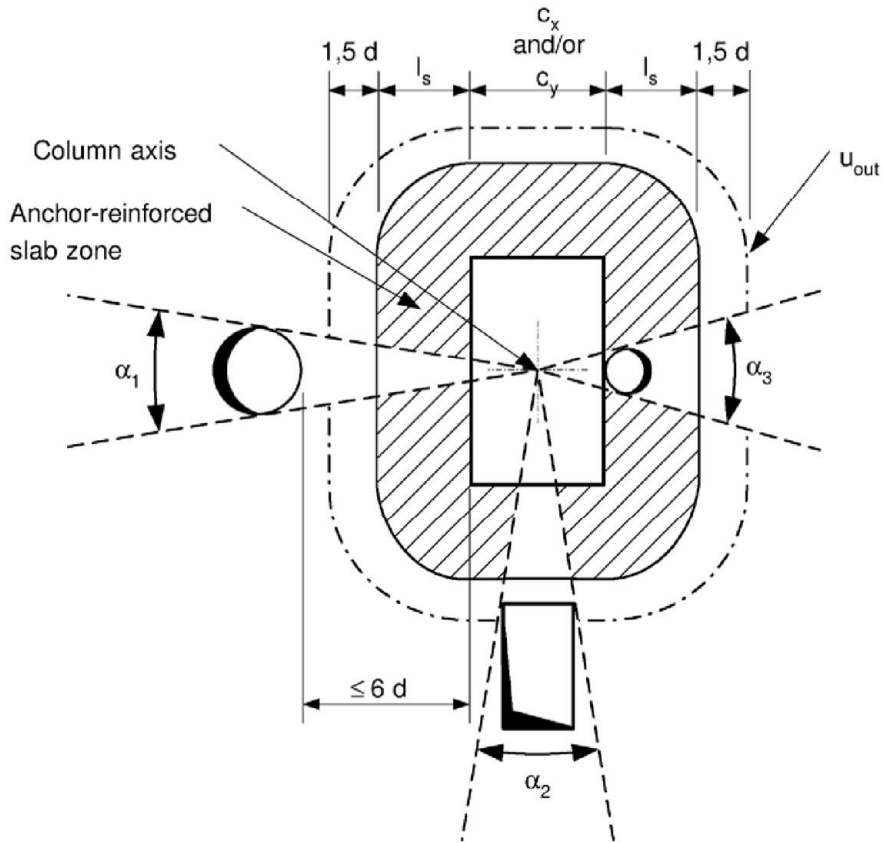

c) Loaded area (column) located close to free edges:

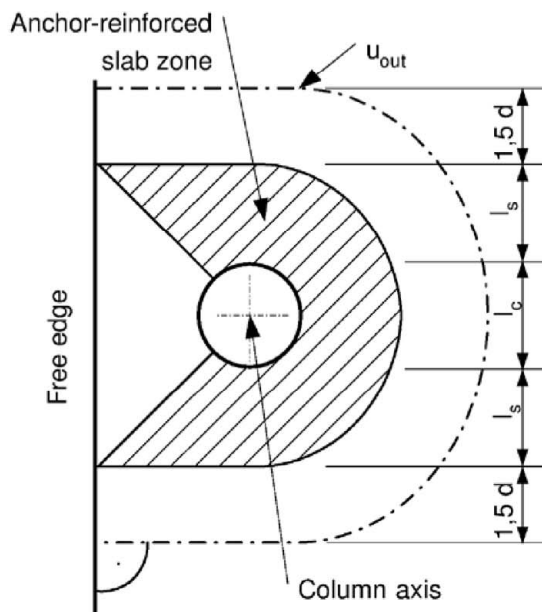

ancoPLUS® punching shear reinforcement

Openings

Annex C3